

---

**Tutorial: Creating a New Case Page 1 of 13**

---

This procedure describes how to create a simple power system model using PowerWorld Simulator. This procedure was developed for use with version 13 and later of the package. If you have an earlier version, please contact PowerWorld Corporation at [info@powerworld.com](mailto:info@powerworld.com) for information on upgrading, or visit the website at <http://www.powerworld.com>.



To begin, double-click on the PowerWorld Simulator icon.  This starts Simulator. Simulator is used to create new cases, modify existing cases, and (of course) simulate power systems. In this example, we will build a new case from scratch. To create a case from an existing power flow case instead, please see [Creating a Case from an Existing Power Flow File](#).



To create a new case, select **New Case** from PowerWorld icon  in the upper left corner of the program. The screen background will turn white, the default background color for new PowerWorld oneline diagram. Oneline diagrams are used in power system analysis to represent the actual three-phase power system using a single line to represent each three-phase device.

---

**Tutorial: Inserting a Bus Page 2 of 13**

---

The most important component of the power system model is the *bus*. Buses are used to represent junction points in the power system where a number of devices are connected together. In building a power system model using Simulator, you will draw buses onto the oneline diagram, attach devices such as generators and loads to the buses, and connect different buses together with transmission lines and transformers.

To insert a bus:

- Select **Network > Bus** from the [Individual Insert](#) ribbon group on the [Draw](#) ribbon tab. This prepares Simulator to insert a new bus.
- Left-click on the oneline background at the location where you want to place the new bus. This invokes the [Bus Option Dialog](#) (pictured below), which is used to specify the name, orientation, shape, size, width, area, zone, and nominal voltage of the bus, as well as the load and shunt compensation connected to the bus .

**Bus Options**

Insert new bus in data model

Bus Number: 1    Find By Number    Find ...

Bus Name: One    Find By Name

Nominal Voltage: 138.00 kV

Labels ...

	Number	Name
Area	1	1
Zone	1	1
Owner	1	1
Substation		

Bus Information    **Display**    Attached Devices    Custom

Orientation:  Right     Up     Left     Down

Shape:  Rectangle     Ellipse

Size: 5.00    Width: 0.200    Scale Width with Size:

Link to New Bus

OK    Save    Cancel

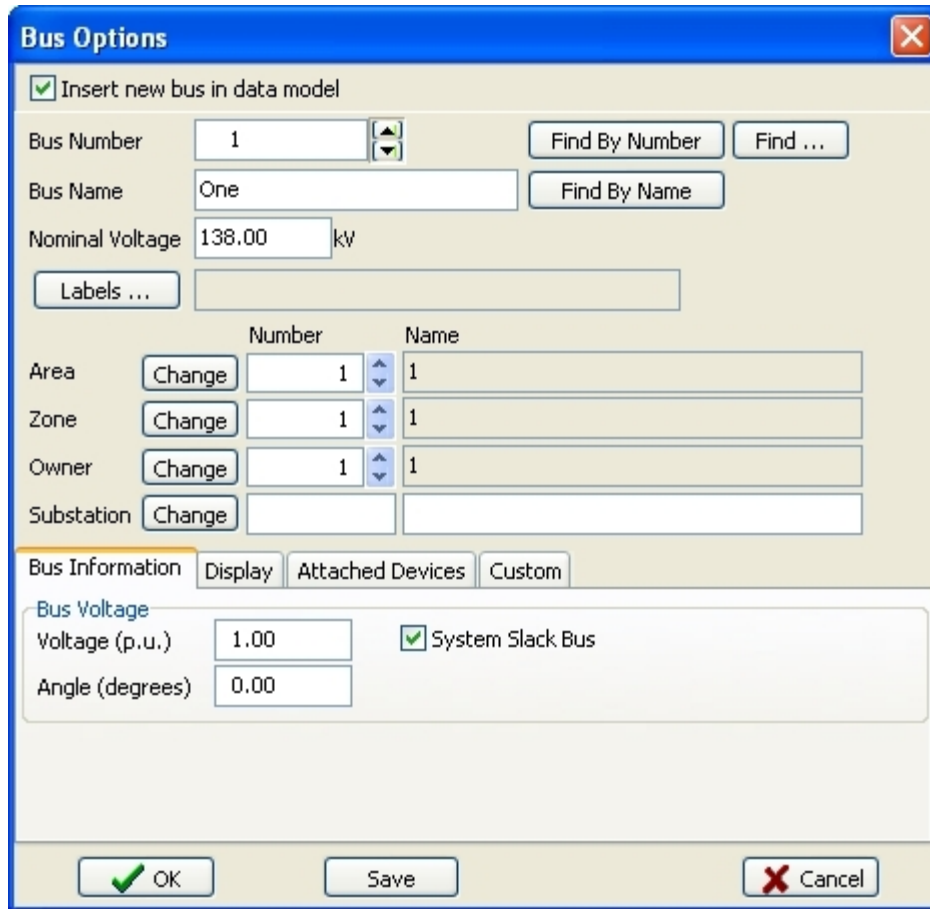

**Bus Options**

Insert new bus in data model

Bus Number: 1 [Find By Number] [Find ...]

Bus Name: One [Find By Name]

Nominal Voltage: 138.00 kV [Labels ...]

	Change	Number	Name
Area	[Change]	1	1
Zone	[Change]	1	1
Owner	[Change]	1	1
Substation	[Change]		

Bus Information: [Display] [Attached Devices] [Custom]

Bus Voltage

Voltage (p.u.): 1.00  System Slack Bus

Angle (degrees): 0.00

[OK] [Save] [Cancel]

- The *Bus Number* field automatically displays '1'. Simulator requires that each bus have a unique number. For convenience, accept the default value. Historically, the *Bus Name* field was limited to eight characters. That limitation is no longer imposed in Simulator. Many users still choose to limit the bus name to eight characters by convention and for ease in converting cases to other formats (such as .epc or .raw). For this example, enter '**One**'.
- Next, check the *System Slack Bus* field, which is located in the Bus Voltage portion of the Bus Information Tab. The Slack Bus is a modeling construct that ensures that the power system has enough generation to meet the load. In other words, the slack bus "picks up the slack" caused by system losses or unbalanced generation and load.
- Click **OK** on the Bus Option Dialog to finish creating the bus and to close the dialog. After the dialog box closes, the new bus appears on the oneline at the location you specified.

---

**Tutorial: Inserting a Generator Page 3 of 13**

---

Next we are going to attach a generator to the bus. Generators may be inserted in a manner similar to inserting a bus:

- Select **Network > Generator** from the [Individual Insert](#) ribbon group on the [Draw](#) ribbon tab.
- Left-click the bus on the oneline diagram to which you want to attach the generator (for this example, click on the slack bus – bus *One*.) The [Generator Option Dialog](#) (pictured below) will automatically open. The dialog is used to specify the new generator's unit identifier, display size, orientation, MW output and limits, reactive power limits, set point voltage, and cost model.

**Generator Options**

Bus Number: 1  
 Bus Name: One  
 ID: 1  
 Area Name: 1  
 Labels ...  
 Find By Number  
 Find By Name  
 Find ...  
 Status:  Open,  Closed  
 Fuel Type: Unknown  
 Unit Type: UN (Unknown)

Display Information | **Power and Voltage Control** | Costs | Fault Parameters | Owner, Area, Zone, Sub | Custom

**Power Control**

MW Output: 413  
 Min. MW Output: 0.000  
 Max. MW Output: 1000.000  
 Available for AGC  
 Enforce MW Limits  
 Part. Factor: 10.00  
 MW Ramp Limit: 20.0

**Voltage Control**

Mvar Output: 0.000  
 Min Mvars: -9900.000  
 Max Mvars: 9900.000  
 Available for AVR  
 Use Capability Curve  
 Regulated Bus Number: 1  
 SetPoint Voltage: 1.0000  
 Remote Reg %: 100.0

MW									
Min Mvar									
Max Mvar									

OK Save Cancel Help

- Every generator must have a *MW Output* specified when the generator is inserted. Make sure the *MW and Voltage Control* tab is selected. Enter '413' in the *MW Output* Field. Note: the *MW Output* specified for a generator connected to the system slack bus is arbitrary because the generator's true output depends on system load and losses.
- Select the *Display Information* tab. The *Orientation* field is used to specify the direction the generator will extend from the bus. The *Anchored* checkbox forces the generator to move with its specified bus when repositioning the bus on the oneline.

- Click **OK** on the Generator Option Dialog to accept the default values for all other fields. After the dialog box closes, the new generator will appear on the oneline attached to the previously selected bus. The oneline diagram should resemble the image shown below.

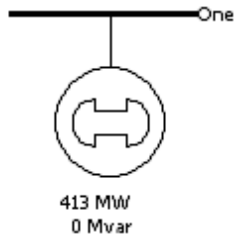

---

**Tutorial: Saving the Case Page 4 of 13**

---

To save the work that we have done so far, select **Save Case** from the [Application Button](#), or click on the *Save Case*  button. Before the case is saved, Simulator validates the case to make sure that it does not contain any errors. Results from this validation are displayed in the Message Log display, usually shown in the lower right-hand corner of the display. If the log is not visible, click the **Log** on the Log group under **Tools**. Since we have not yet named the case, the **Save As** dialog is displayed. Enter a file name and select **OK**. By default the case is saved using the [PowerWorld Binary format](#) (\*.pwb). When saving the case in the future, you will not have to reenter its name. Simulator also asks you to supply a name for saving the oneline diagram we have been drawing. The oneline diagram files have a default extension of \*.pwd, which identifies them as PowerWorld Display files. Supply the same name as you gave to the case. Note that, because the case and the oneline are stored in separate files, multiple onelines can be assigned to the same case, and the same oneline can be used by many cases.

---

**Tutorial: Entering a Second Bus with Load Page 5 of 13**

---

To enter the second bus:

- Select **Network > Bus** from the [Individual Insert](#) ribbon group on the [Draw](#) ribbon tab.
- Click on the oneline diagram somewhere to the right of the first bus. In the Bus Options Dialog (pictured below) leave the bus number at the default value of **2**, and enter the name '**Two**' in the *Bus Name* field.
- We will model a 200 MW, 100 Mvar load at the bus. Select the *Attached Devices* tab. Under the *Load Summary Information* heading enter '**200**' in the *Base MW* field and '**100**' in the *Base Mvar* field.
- Click **OK** to accept all other default values, close the Bus Options Dialog, and insert the bus.

The screenshot shows the 'Bus Options' dialog box with the following fields and values:

- Bus Number:** 2
- Bus Name:** Two
- Nominal Voltage:** 138.0 kV
- Labels:** no labels
- Area:** 1
- Zone:** 1
- Owner:** 1
- Substation:** (empty)
- Attached Devices Tab:**
  - Load Summary Information:**
    - Base MW: 200.0
    - Base Mvar: 100.0
  - Shunt Admittance:**
    - G (MW): 0.0
    - B (Mvar): 0.0

At this point, the oneline diagram does not show the load at bus 2, even though it is represented in the power system model (you can confirm this by right-clicking on bus 2, selecting *Bus Information Dialog* from the resulting local menu, and inspecting the *Load Summary Information* fields again).

To draw the load on the oneline diagram:

- Select **Network > Load** from the [Individual Insert](#) ribbon group on the [Draw](#) ribbon tab.
- Left-click in the center of this bus. The Load Options Dialog box (pictured below) automatically opens. The *Constant Power MW* and *Mvar* fields confirm that the load is 200 MW and 100 Mvar. In addition to constant power loads, Simulator also allows the modeling of voltage dependent loads.

**Load Options**

Bus Number: 2   Open  
 Bus Name: Two   Closed  
 ID: 1   
 Labels ...: no labels

Area:  1 1  
 Zone:  1 1  
 Substation:    
 Owner:  1 1  
 Same Owner as Terminal Bus

Load Information:

Constant Power: MW Value: 200.000  
 Constant Current: Mvar Value: 100.000  
 Constant Impedance: 0.000

Display Information:  
 Display Size: 10.00  
 Scale Width with Size  
 Display Width: 3.75  
 Pixel Thickness: 1  
 Orientation:  Right  Left  
 Up  Down  
 Anchored

- Select **Up** in the *Orientation* field under the *Load Information* tab to make the load point up. Verify that the anchored box is checked to force the load to move with the selected bus.
- Click **OK** to accept the default values for all remaining fields, close the Load Options dialog, and insert the load. A circuit breaker symbol is automatically included with each load.

To move objects on the oneline:

- Left-click on the desired object. Drag and drop the object to the new location by holding the left mouse button down while moving the mouse. Note: you can also move all objects on the oneline simultaneously by left-clicking on the diagram (not on a specific object) then dragging and dropping in the desired location.
- To move bus 2, left click on bus 2 (not on the attached load). Drag the bus to a new location. Note that the load moves with the bus because it is [anchored](#). You can change the location of attached devices connected to a bus, such as generators and loads, by the same procedure.

The oneline diagram should now resemble the image shown below.

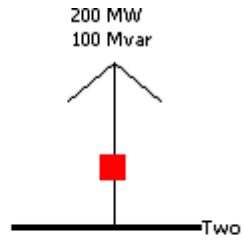
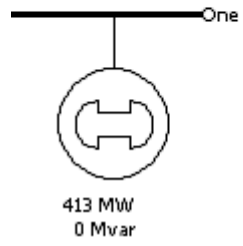

---

**Tutorial: Inserting a Transmission Line Page 6 of 13**

---

Transmission lines are used to connect buses together. To insert a transmission line:

- Select **Network > Transmission Line** from the [Individual Insert](#) ribbon group on the [Draw](#) ribbon tab.
- Left-click at the point where you want the new line to originate. This point is usually located on one of the proposed line's terminal buses. For this example, originate the line at bus One.
- Transmission lines and transformers are drawn as a series of line segments. Without holding down the mouse button, drag the mouse up. Notice that a line segment connected to the point of origin will follow your mouse movements. To terminate a line segment, click the left mouse button. Each time you click the mouse to terminate a line segment, a new vertex is defined for the line. To draw the next line segment, move the mouse to the desired location of the next vertex. Note: the vertices may later be moved or deleted to reshape the line. To create curved lines, hold the left mouse button down while dragging.
- To terminate the final line segment and conclude drawing the line, double click the left mouse button at the desired termination point (bus Two for this example). The termination point is usually the transmission line's other terminal bus.
- The [Transmission Line/Transformer Dialog](#) automatically appears (shown below). The dialog should already contain a **1** in the *From Bus Number* field and a **2** in the *To Bus Number* Field. If not, you probably did not have the cursor directly on the bus when you were drawing the line. If this is the case, simply enter the correct bus numbers in the corresponding fields.

**Transmission Line/Transformer Options**

From Bus: 1, To Bus: 2, Circuit: 1

Number: 1, Name: One, Area Name: 1 (1), Nominal kV: 138.0

Find By Numbers, Find By Names, Find ...

From End Metered

Default Owner (Same as From Bus)

Labels ...

Fault Info, Owner, Area, Zone, Sub, Custom

Display, Parameters, Transformer Control, Series Capacitor

Status:  Open,  Closed

Length (mi): 0.00

Calculate Impedances >

Per Unit Impedance Parameters:

Series Resistance (R): 0.02

Series Reactance (X): 0.08

Shunt Charging (B): 0.1

Shunt Conductance (G): 0.0000

Has Line Shunts

Line Shunts

MVA Limits:

Limit A	1000
Limit B	0.000
Limit C	0.000
Limit D	0.000
Limit E	0.000
Limit F	0.000
Limit G	0.000
Limit H	0.000

Convert Line to Transformer

OK, Save, Cancel, Help

- The *Series Resistance*, *Series Reactance*, and *Shunt Charging* fields are used to enter the per unit parameters associated with the line. The *Shunt Charging* field contains the total per unit charging capacitance for the line. Enter **0.02** in the *Resistance* field, **0.08** in the *Reactance* field and **0.1** in the *Shunt Charging* field.
- The *Limit (MVA)* fields contain the MVA ratings for the line; enter a value of 1000 in the *Limit A (MVA)* field.
- Click **OK** to accept all remaining field default values, close the Transmission Line/Transformer Dialog, and insert the new line.

By default, the transmission line is anchored to both terminal buses. If you try to move bus 2, the transmission line should move with it.

---

**Tutorial: Inserting a Line Flow Pie Chart on a Transmission Line Page 7 of 13**

---

When the line is drawn it automatically it has a line flow pie chart included. You can include additional line flow pie charts by selecting **Pies/Gauges > Line Flow Pie Chart** from the [Individual Insert](#) ribbon group on the [Draw](#) ribbon tab, and then clicking near a line. The Line/Transformer Flow Pie Chart dialog box appears (shown below). Make sure that the From Bus and To Bus have the correct numbers, that the MVA rating is correct, and that Anchored is checked. You may change the size of the pie chart by typing in a value or using the arrows.

Color and behavior of pie charts are set in the *Oneline Display Options* display; right-click anywhere in the background of the oneline, select *Oneline Display Options* from the pop-up menu, then select the *Pie Charts* tab (pictured below).

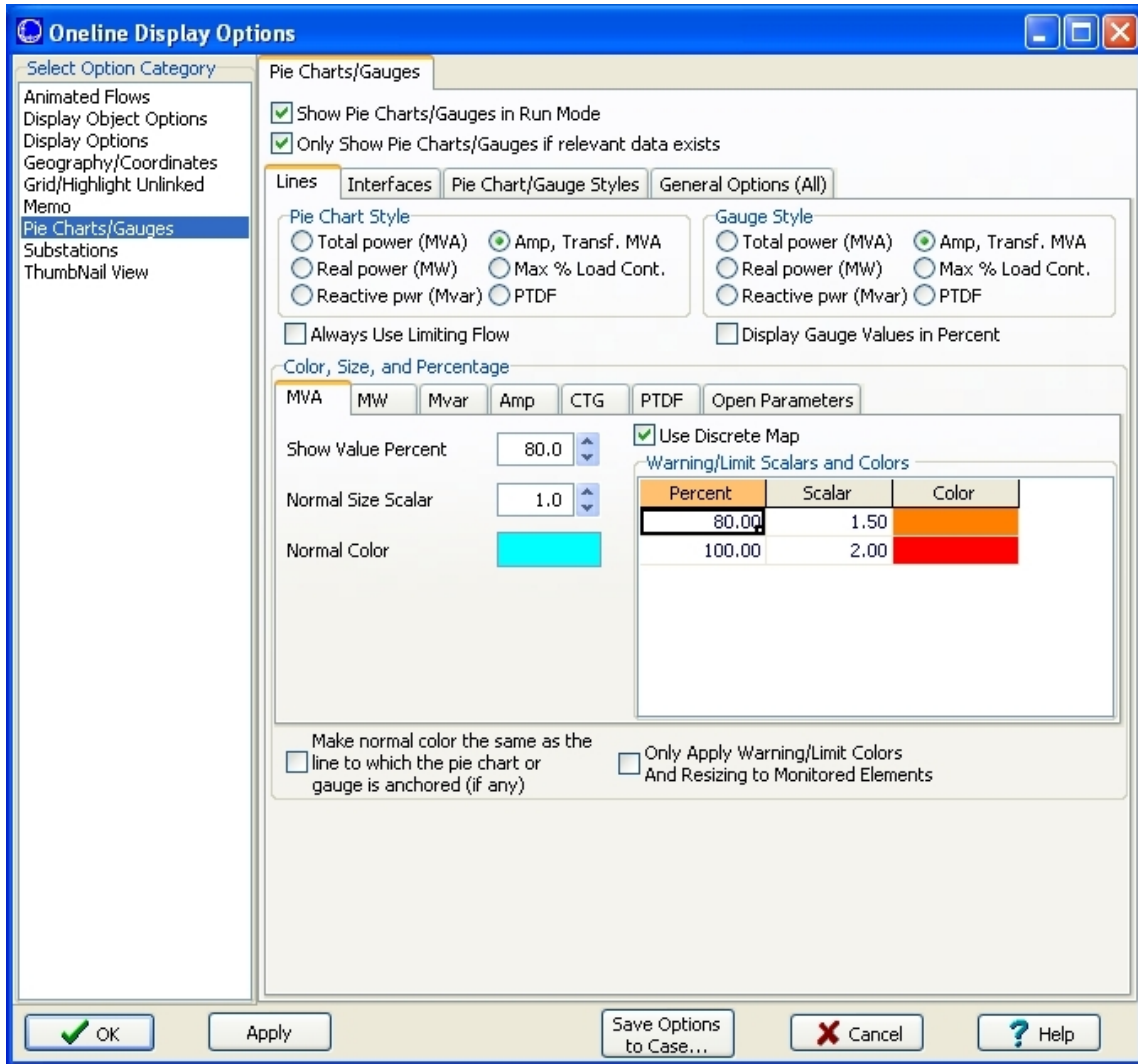

---

**Tutorial: Inserting Circuit Breakers Page 8 of 13**

---

Circuit breakers are used to control the status of the line. (If the line already has circuit breakers at each end, then Simulator has been instructed to insert circuit breakers automatically. You can configure this option from the [Default Drawing Options Dialog](#)).

To insert a Circuit Breaker:

- Click somewhere on the line near bus One then select **Indication > Circuit Breaker** from the [Individual Insert](#) ribbon group on the [Draw](#) ribbon tab, then click on the line near bus One. You should immediately see the Circuit Breaker Options dialog (shown below) with the From Bus and To Bus fields correctly set to '1' and '2'. If they are '0', enter the correct value. Set the Size field to '1' (you can either enter a 1, or use the spin arrows to change the value).
- Click **OK** to insert the circuit breaker.

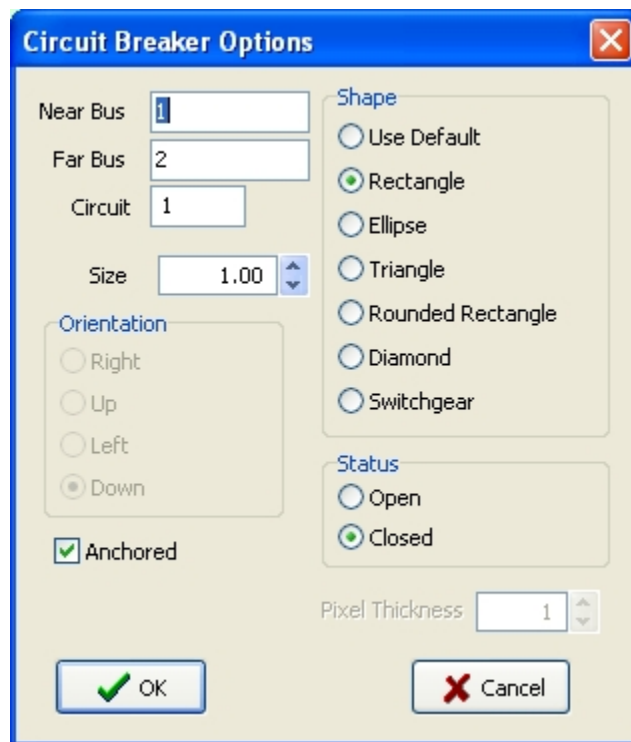

In Simulator, the location of the circuit breaker does not matter, because changing the status of the circuit breaker changes the status of the entire line. However, since most transmission lines have circuit breakers at each end, we will also place a circuit breaker near bus 2. To accomplish this, repeat the above process near bus 2.

**Save your case.** Your oneline should now look similar to the image below.

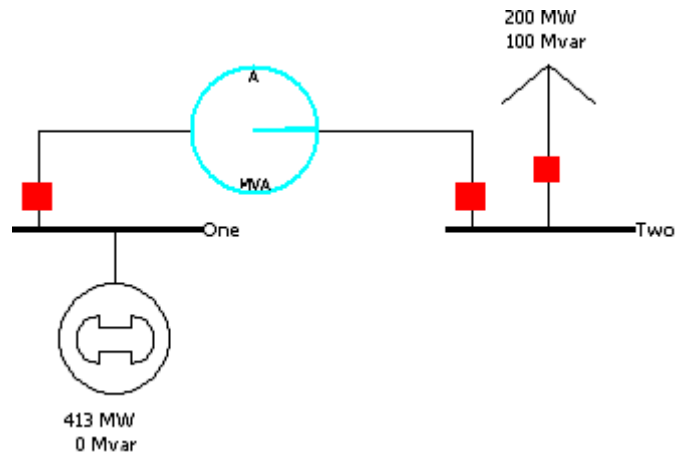

---

**Tutorial: Inserting a Transformer Page 9 of 13**

---

To insert a transformer we first need to insert a bus at a different voltage level. Insert a new bus in the bottom of the oneline, named **Three**, and enter **69** KV for its nominal voltage in the Bus Options dialog box.

To insert a transformer between buses 2 and 3:

- Either go to **Network > Transformer** from the [Individual Insert](#) ribbon group on the [Draw](#) ribbon tab.
- Click on bus 2, and then draw a line to bus 3 as you did for a transmission line. The [Transmission Line/Transformer Dialog](#) automatically appears.

- On the **Parameters** tab, enter **0.02** for *Series Resistance*, **0.08** for *Series Reactance*, **0.1** for *Shunt Charging* and **1000** for *Limit A (MVA)*.
- Select the **Transformer Control** tab. Note that the Off-nominal Turns Ratio displays **1.000**. The true transformer turns ratio does not need to be specified as it is automatically determined by the

ratio of nominal voltages between the *From Bus* and *To Bus*. The *Off-nominal Turns Ratio* is used to adjust the transformer tap setting on per-unit values of bus voltages as referenced to their respective base values for per-unit calculation.

- Click **OK** to accept the default values, close the dialog and insert the transformer.
- Repeat this procedure to add a transformer between buses 1 and 3.

Add a 400 MW, 200 Mvar load to bus 3:

- Right-click on bus 3 and select **Bus Information Dialog**. Select the **Attached Devices** tab. Click **Add or Edit Bus Load**.
- Under *Constant Power* enter **400** in the *MW Value* field. Enter **200** in *Mvar Value* field. Click **OK**.
- Note that *Base MW* and *Base Mvar* display the respective values. Click **OK**.

The load is now attached to the bus even though it is not displayed on the oneline. To display the load as an object on the oneline, you can either use the **Auto Insert** feature or follow the procedure utilized earlier. To **Auto Insert** the load:

- Select **Auto Insert > Loads...** from the [Quick Insert](#) ribbon group on the [Draw](#) ribbon tab. The *Automatic Insertion of Loads* dialog opens automatically.
- Click **OK** to accept the default values and insert the load object on the oneline.

Note that Lines, Loads, Interfaces, Generators and Switched Shunts can all be inserted as objects on a oneline using the **Auto Insert** tool if a record already exists for the device.

- Left-click and drag the load to the desired location on bus 3. Note: you can resize the bus object on the oneline by left-clicking on the bus then dragging either end-point vertex to the desired bus size.
- Right-click on the load and select **Load Information Dialog**. You can change the load orientation and verify all load parameters in this dialog.
- Click **OK**.

Next we are going to attach a 300 MW generator to the bus 3:

- Select **Network > Generator** from the [Individual Insert](#) ribbon group on the [Draw](#) ribbon tab.
- Left-click on bus 3. The [Generator Option Dialog](#) opens.
- Select the *Power and Voltage Control* tab. Enter '**300**' in the *MW Output* Field.
- Click **OK** on the Generator Option Dialog to accept the default values for all other fields. After the dialog box closes, the new generator appears on the oneline attached to bus 3.

Your oneline should now resemble the image shown below.

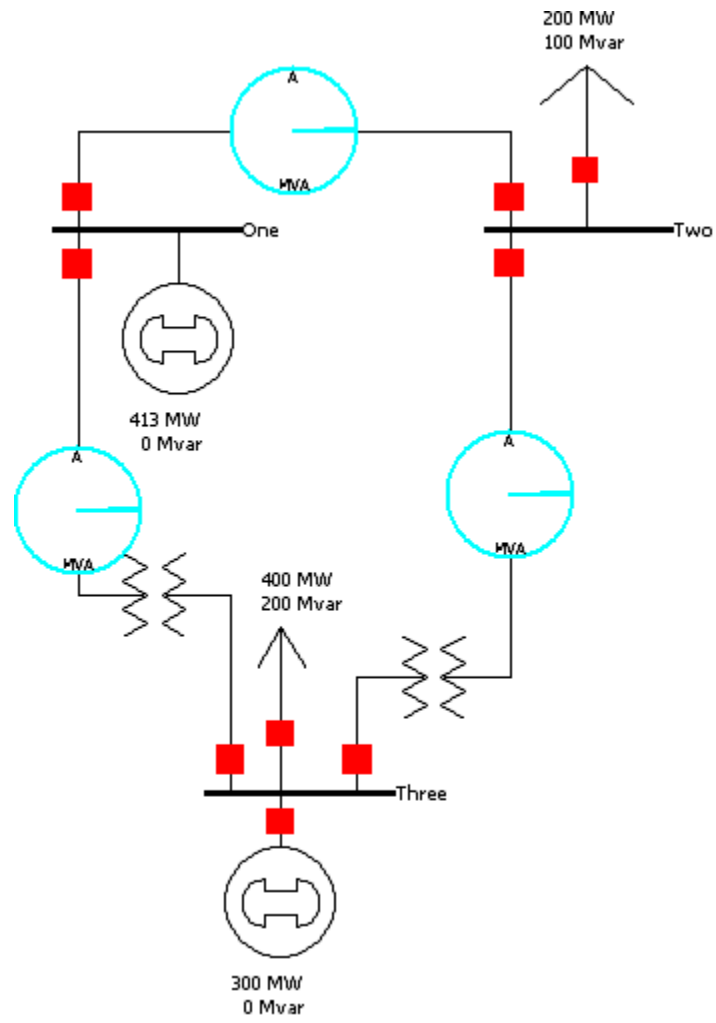

---

**Tutorial: Inserting a Switched Shunt Page 10 of 13**

---

Switched shunts usually consist of either capacitors to supply reactive power (in MVAR) to the system, or reactors to absorb reactive power. The switched shunts are represented by a number of blocks of admittance that can be switched in a number of discrete steps. If at least one block is in service, the shunt is said to be online. The shunt's corresponding circuit breaker is used to determine and / or toggle the switched shunt's status.

- To insert a switched shunt at bus 3, select **Network > Switched Shunt** from the [Individual Insert](#) ribbon group on the [Draw](#) ribbon tab.
- Click on or near bus 3. The *Switched Shunt Options* dialog box appears (pictured below).
- Verify that the bus number is 3; if it is not, change it.
- Enter **10** for the *Nominal Mvar*.
- Click **OK** to accept the default values of the remaining fields, close the dialog, and insert the switched shunt.

**Switched Shunt Options**

Bus Number: 3

Bus Name: Three

Shunt ID: 1

	Number	Name
Area	1	1
Zone	1	1
Substation		

Display Parameters Control Parameters Fault Parameters Custom

Nominal Mvar:

Control Mode:  Fixed  Discrete  Continuous  Bus Shunt (Fixed)

Control Regulation Settings:  Voltage  Generator Mvar

High Value: 1.0000  
Low Value: 0.9900  
Reg. Bus #:  Target Value: 1.0000

Switched Shunts Blocks

Number of Steps	Mvars per Step

Your oneline should now look similar to the image below.

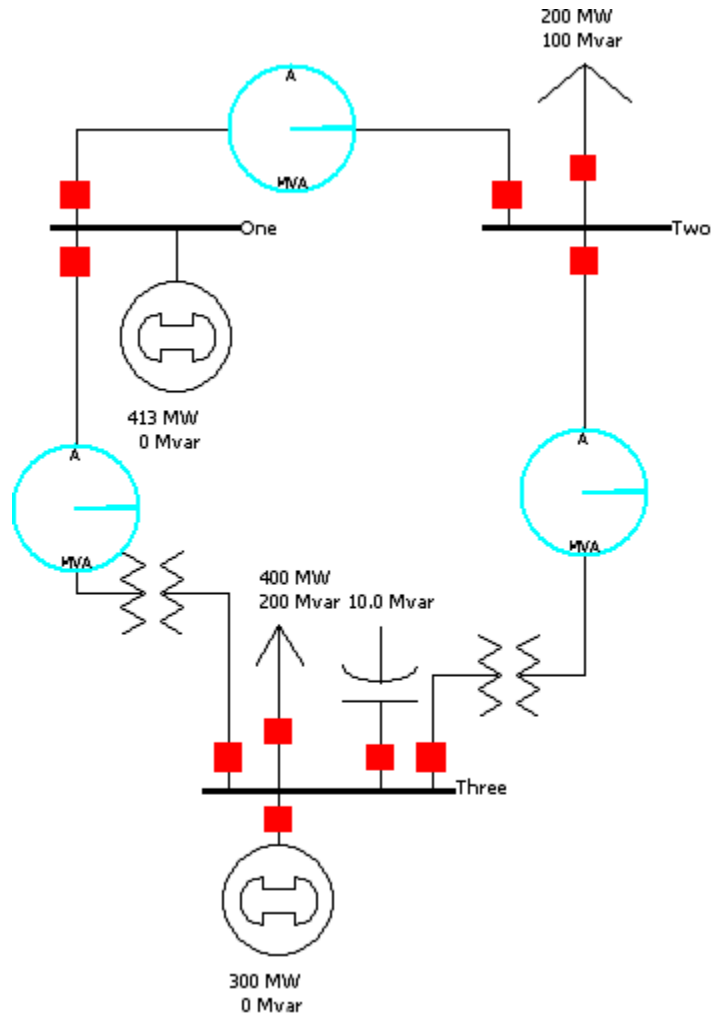



---

**Tutorial: Inserting Text, Bus and Line Fields Page 11 of 13**

---

Informational fields can be entered directly on the oneline to allow for ease of monitoring when a case is animating.

To insert a general text field:

- Select **Background > Text** from the [Individual Insert](#) ribbon group on the [Draw](#) ribbon tab. Left-click on the oneline in the desired text location to bring up the *Text Object Dialog*. (For this example, left-click in the top center of the oneline.)
- Type the string "First Case" in the *Enter the text* field. Click **OK**.
- To format the text, ensure the text is selected on the one-line then select  from the [Formatting](#) ribbon group on the [Draw](#) ribbon tab. This displays the [Font Tab](#) of the [Format Selection Dialog](#).
- Set the font size to **26** and the font color to **blue**.
- To change the text background color, select  from the [Formatting](#) ribbon group on the [Draw](#) ribbon tab, which summons the Line/Fill Options Tab . If the format menu is already open, click on the [Line/Fill Options Tab](#) of the Format Selection Dialog. Check the *Use Background Fill* box to give the text a white background, and then click *OK*.
- Inserted text can be moved using the same method as any other object on the oneline

Fields can also display object-related quantities. By default, Simulator has inserted the bus names, generator and load MW and MVAR, and switched shunt MVAR. For this example, we will add a Bus Voltage Magnitude field to each bus and fields showing the power flow on the transmission line and the transformers. Note that object fields can be formatted just like text fields by using the Format menu.

To add additional fields to the display of a particular bus:

- Right-click on the bus to bring up the bus' local menu.
- Select *Add New Fields Around Bus* from the local menu. This opens the [Insert Bus Fields Dialog](#) (pictured below). You may add up to 8 fields per bus. Select the position where you would like to add the new field (position 5 for this example) then click **OK**.

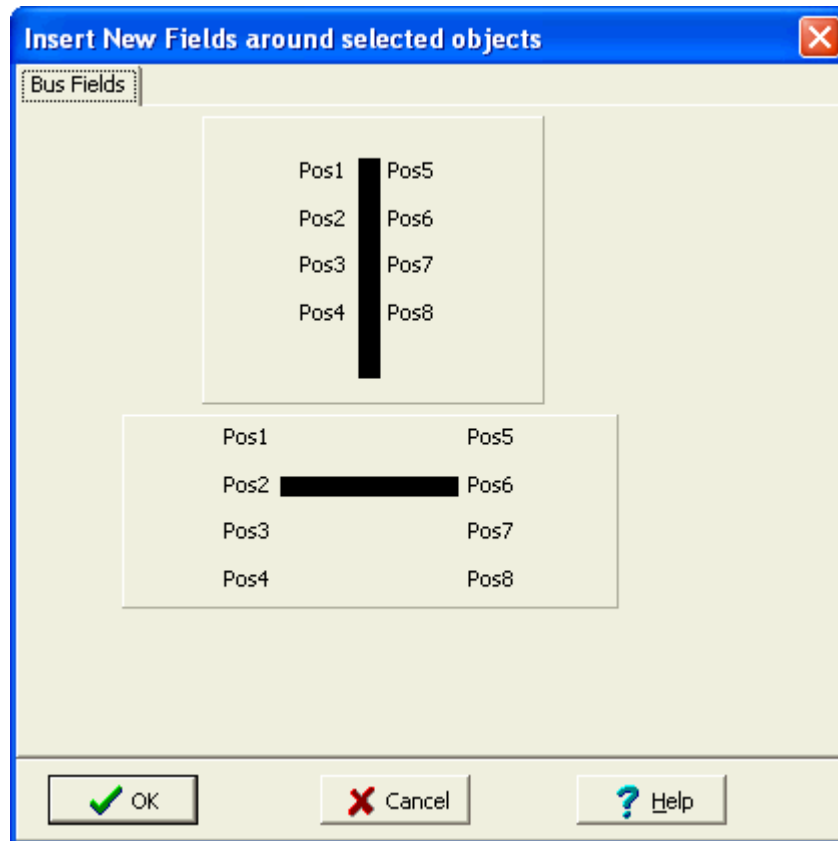

- This opens the Bus Field Options dialog (shown below); select the field **Bus Voltage** to add in the selected position and click **OK**.

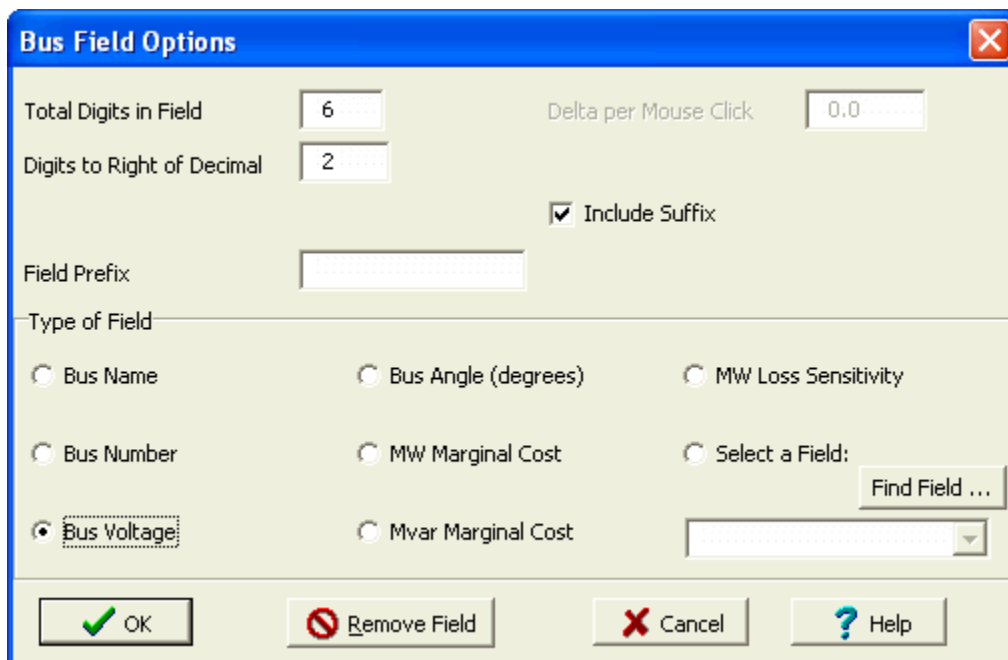

- The parameter and position are displayed as highlighted in the Insert New Fields dialog. Click **OK**. Note that the specified bus field has been added to the oneline diagram.
- Repeat this procedure for the other two buses. If necessary, you may move fields manually with the mouse.

Fields can also be inserted using the **Background > Field** option from the [Individual Insert](#) ribbon group on the [Draw](#) ribbon tab.

Next, we will insert fields showing the power flow at each end of the transmission line.

- Select **Field > Transmission Line Field** from the [Individual Insert](#) ribbon group on the [Draw](#) ribbon tab.

Line fields show information about transmission lines and transformers. For line fields, flow is always specified at an end of the transmission line or transformer. The end is normally determined automatically by the insertion point.

- Left-click near both bus **1** and the transmission line between buses 1 and 2 in the location you want the power flow text to appear. The *Line Field Options* dialog (shown below) opens automatically.
- The *Near Bus* and *Far Bus* fields should show **1** and **2** respectively. If they do not, enter the correct values.
- Select **MW Flow** then click **OK**. The field is displayed on the oneline in the location you specified. Note that the field can be moved and formatted as previously discussed.
- Select **Field > Transmission Line Field** from the [Individual Insert](#) ribbon group on the [Draw](#) ribbon tab.
- Left-click near both bus **2** and the transmission line between buses 1 and 2 in the location you want the power flow text to appear. The *Line Field Options* dialog (shown below) opens automatically.
- Now the *Near Bus* and *Far Bus* fields should show **2** and **1** respectively. If they do not, enter the correct values.
- Select **MW Flow** then click **OK**.
- Repeat the procedure to insert **Mvar Flow** fields for the two locations.

We also desire to monitor the MW and Mvar flows on the lines joining buses 1 and 3 and buses 2 and 3 via the transformers. The same commands are used as those used to insert fields for the transmission line.

- Repeat the above steps to insert **MW** (and **Mvar**) **Flow** fields on the lines joining buses 1 and 3 and buses 2 and 3 via the transformers.
- At this point, your first oneline diagram should resemble the one shown below.

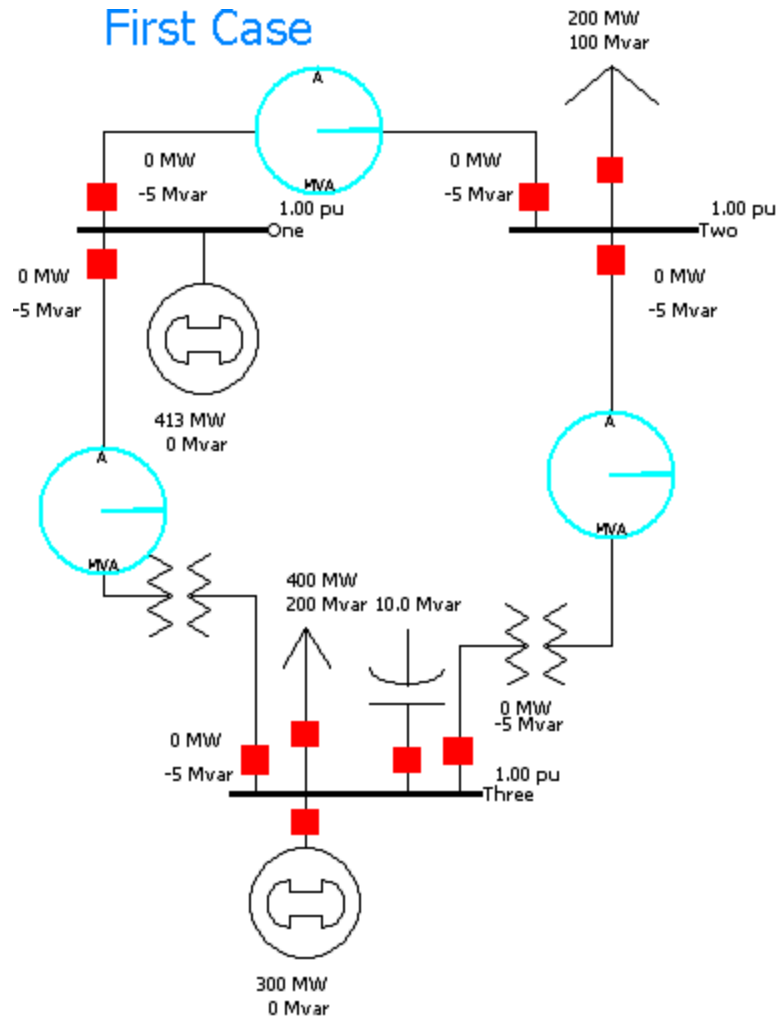

- Save the case.

---

**Tutorial: Solving the Case Page 12 of 13**

---

To solve a case, you must be in run mode:

- Click on **Run Mode** button in the **Mode** ribbon group. Note that if the case has [validation errors](#), a warning will appear. You will need to rectify the problems before you can enter Run Mode.
- Press the **Play**  button in the **Power Flow Tools** ribbon group on the [Tools](#) ribbon tab to begin the simulation. Alternatively, to perform a single Power Flow Solution, click the **Single Solution - Full Newton** button in the **Power Flow Tools** ribbon group on the [Tools](#) ribbon tab. Your case should look similar to the case shown below. If it does, congratulations! You have completed building your first case.

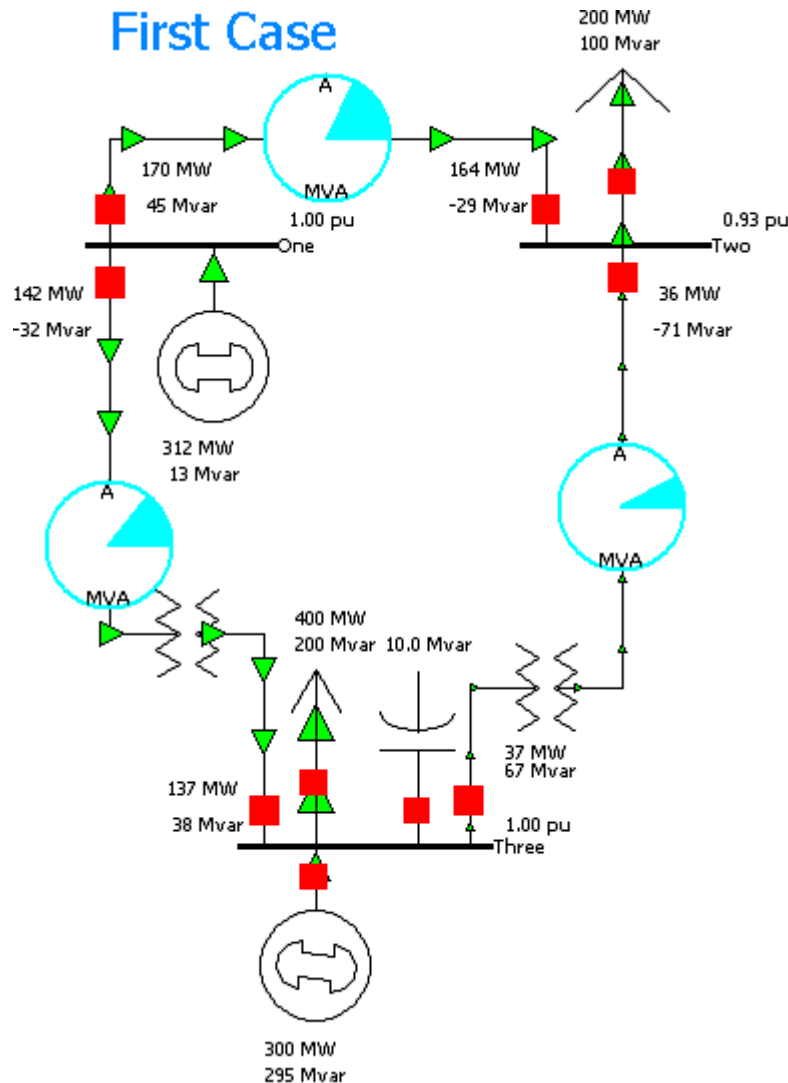

Try clicking on the load circuit breaker to toggle the load's status. A solid red circuit breaker indicates that it is closed, a hollow green box indicates it is open. While the simulation is running, click on the circuit breakers and note the nearly instantaneous change in system flows. If the Log window is

visible, you will get a "backstage" view of what Simulator is doing. Feel free to close the log. To re-open the log, click the **Log** button in the **Log** ribbon group on the [Tools](#) ribbon tab.

With the load circuit breaker closed, open the circuit breaker between bus 3 and its connected generator. Now open any of the transmission line or transformer circuit breakers.

Congratulations, you've just blacked-out your case!